

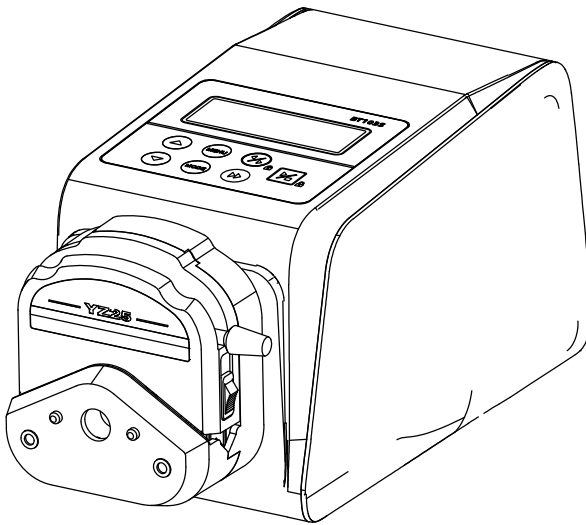

BT103S Variable-Speed Pump Operating Manual



Contents

Safety Precautions	1
1 Description	6
2 Functions and Features.....	6
3 Components and Connectors.....	8
4 Display Panel and Operating Keypad.....	9
4.1 Keypad.....	9
4.2 LCD Screen Display.....	10
5 Parameter Settings.....	12
6 External Control Interface.....	15
7 Operation Instructions	15
7.1 Before Operating.....	15
7.2 Power Connection.....	16
7.3 Change Control Mode	16
7.4 Internal Control Mode.....	17
7.5 External Control Mode.....	17
7.6 Time Dispense Mode.....	19
7.7 Logic Level 1 Control Mode (footswitch).....	20
7.8 Logic Level 2 Control Mode (footswitch and direction switch). 21	
7.9 Communication Mode	23
7.10 Set Speed	24
7.11 Wi-Fi Network Setting.....	24
8 Maintenance	25
8.1 Warranty	25
8.2 Regular Maintenance	25
8.3 Malfunction Solutions	26
9 Dimensions	27
10 Naming Rule	28
11 Specifications	28

Safety Precautions



Danger

- Use the correct voltage indicated on the rating plate label of the pump to avoid any damage.
- Do not make any unauthorized dismantling, changes or modifications to the pump which could result in malfunctions or even potential accidents.
- Turn off the pump drive before installing or removing tubing, attempting any maintenance, cleaning or repair of the drive, connecting or disconnecting external control devices or a communication interface. Fingers or loose clothing could get caught in the drive mechanism.



Warning

- Ensure no chemical reactions occur between the handled fluid with the material of the pump head and tubing before use.
- Tubing should be checked regularly to avoid breakage. Tubing breakage may result in fluid being sprayed from the pump. Use appropriate measures to protect the operator and equipment. The operator is solely liable for damages resulting from tubing breakage, particularly the leakage of toxic or valuable liquids.
- The pump is provided with a grounded plug which must be well grounded at all times.
- This device is not designed for nor intended for usage in patient connected applications, including but not limited to medical and dental use.
- Observe all other applicable regulations concerning working safety, operational safety, environmental protection and relevant local regulations.

(DE) SICHERHEITSHINWEISE



Gefahr

- Verwenden Sie die richtige Spannung, die auf dem Typenschild der Pumpe angegeben ist, um Schäden zu vermeiden.
- Nehmen Sie keine unbefugten Demontagen, Änderungen oder Modifikationen an der Pumpe vor, die zu Fehlfunktionen oder sogar zu Unfällen führen könnten.
- Schalten Sie den Pumpenantrieb aus, bevor Sie Schläuche ein- oder ausbauen, Wartungs-, Reinigungs- oder Reparaturarbeiten am Antrieb vornehmen oder externe Steuergeräte oder eine Kommunikationsschnittstelle anschließen oder trennen. Finger oder lose Kleidungsstücke können sich im Antriebsmechanismus verfangen.



Warnung

- Vergewissern Sie sich vor der Verwendung, dass keine chemischen Reaktionen zwischen dem Fördermedium und dem Material des Pumpenkopfs und der Schläuche auftreten können.
- Die Schläuche sollten regelmäßig überprüft werden, um Brüche zu vermeiden. Ein Schlauchbruch kann dazu führen, dass Flüssigkeit aus der Pumpe spritzt. Ergreifen Sie geeignete Maßnahmen zum Schutz des Bedieners und der Ausrüstung. Der Betreiber haftet allein für Schäden, die durch einen Schlauchbruch entstehen, insbesondere für das Austreten von giftigen oder wertvollen Flüssigkeiten.
- Die Pumpe ist mit einem geerdeten Stecker ausgestattet, der stets korrekt an eine abgesicherte Netzsteckdose angeschlossen sein muss. Dieses Gerät ist nicht für Anwendungen ausgelegt oder vorgesehen, die im Zusammenhang mit der Behandlung von Patienten stehen. Medizinische bzw. zahnmedizinische Anwendungen sind nicht bestimmungsgemäß.
- Beachten Sie alle anderen geltenden Vorschriften zur Arbeitssicherheit, zur Betriebssicherheit, zum Umweltschutz sowie die einschlägigen örtlichen Vorschriften.

(FR) CONSIGNES DE SÉCURITÉ



Danger

- Utilisez la tension correcte indiquée sur la plaque signalétique de la pompe afin d'éviter tout dommage.
- Ne procédez pas à des démontages, changements ou modifications non autorisés de la pompe qui pourraient entraîner des dysfonctionnements, voire des accidents.
- Mettez l'entraînement de la pompe hors tension avant d'installer ou de retirer des tuyaux, d'effectuer des travaux d'entretien, de nettoyage ou de réparation sur l'entraînement ou de connecter ou déconnecter des dispositifs de commande externes ou une interface de communication. Des doigts ou des vêtements lâches pourraient se prendre dans le mécanisme d'entraînement.



Avertissement

- Avant toute utilisation, assurez-vous qu'il n'y a pas de réaction chimique entre le liquide pompé et le matériau de la tête de pompe et des tubes.
- Les tuyaux doivent être contrôlés régulièrement pour éviter les ruptures. Une rupture de tuyau peut entraîner des projections de liquide hors de la pompe. Prenez les mesures appropriées pour protéger l'opérateur et l'équipement. L'opérateur est seul responsable des dommages causés par une rupture de tuyau, notamment en cas de fuite de liquides toxiques ou précieux.
- La pompe est équipée d'une fiche de mise à la terre qui doit toujours être bien reliée à la terre.
- Cet appareil n'est pas conçu ni prévu pour être utilisé en présence de patients, y compris, mais sans s'y limiter, dans le cadre d'applications médicales et dentaires.
- Respectez toutes les autres réglementations applicables en matière de sécurité du travail, de sécurité d'exploitation, de protection de l'environnement.

(ES) INSTRUCCIONES DE SEGURIDAD



Peligro

- Utilice la tensión correcta indicada en la placa de características de la bomba para evitar daños.
- No realice ningún desmontaje, cambio o modificación no autorizada en la bomba que pueda provocar un mal funcionamiento o incluso accidentes.
- Desconecte el accionamiento de la bomba antes de instalar o retirar las mangueras, realizar trabajos de mantenimiento, limpieza o reparación en el accionamiento o conectar o desconectar dispositivos de control externos o una interfaz de comunicación. Los dedos o la ropa suelta podrían quedar atrapados en el mecanismo de accionamiento.



Advertencia

- Antes de usarla, asegúrese de que no hay reacciones químicas entre el medio bombeado y el material de la cabeza de la bomba y las mangueras.
- Las mangueras deben ser revisadas regularmente para evitar roturas. La rotura de una manguera puede hacer que salga líquido de la bomba. Tome las medidas adecuadas para proteger al operador y al equipo. El operador es el único responsable de los daños causados por la rotura de una manguera, especialmente por la fuga de líquidos tóxicos o valiosos.
- La bomba está equipada con un enchufe con toma de tierra que debe estar siempre bien conectado a tierra.
- Este aparato no está diseñado ni pensado para su uso en relación con los pacientes, incluyendo pero sin limitarse a las aplicaciones médicas y dentales.
- Respetar todas las demás normas aplicables en materia de seguridad laboral, seguridad operativa y protección del medio ambiente.

(IT) ISTRUZIONI DI SICUREZZA



Pericolo

- Usare la tensione corretta indicata sull'etichetta della targhetta della pompa per evitare qualsiasi danno.
- Non eseguire smontaggi, cambiamenti o modifiche non autorizzati alla pompa che potrebbero causare malfunzionamenti o addirittura potenziali incidenti.
- Spegnerne l'azionamento della pompa prima d'installare o rimuovere tubi, tentare qualsiasi manutenzione, pulizia o riparazione dell'azionamento, collegare o scollegare dispositivi di controllo esterni o un'interfaccia di comunicazione. Dita o indumenti larghi potrebbero rimanere impigliati nel meccanismo di azionamento.



Attenzione

- Assicurarsi che non si verifichino reazioni chimiche tra il fluido trattato e il materiale della testa della pompa e dei tubi prima dell'uso.
- I tubi devono essere controllati regolarmente per evitare rotture. La rottura del tubo può provocare spruzzi di fluido dalla pompa. Utilizzare misure appropriate per proteggere l'operatore e l'attrezzatura. L'operatore è l'unico responsabile dei danni derivanti dalla rottura dei tubi, in particolare della fuoriuscita di liquidi tossici o preziosi.
- La pompa è dotata di una spina con messa a terra che deve essere sempre ben collegata a terra.
- Questo dispositivo non è progettato né destinato all'uso in applicazioni collegate al paziente, incluso ma non limitato all'uso medico e dentistico.
- Osservare tutte le altre norme applicabili riguardanti la sicurezza sul lavoro, la sicurezza operativa, la protezione dell'ambiente e le norme locali pertinenti.

1 Description

The BT103S variable-speed peristaltic pump not only has basic functions such as start/stop, speed control, prime and reversible direction, but also upgraded to LCD display, adds time dispense mode and anti-drip function, and can be easily controlled by the RS485 communication of the MODBUS protocol.

BT103S flow range 0.00011-480 mL/min, speed 0.1-10 0 rpm.

2 Functions and Features

Advantage of peristaltic pump: Peristaltic pump can handle extremely viscous fluids, abrasive slurries and corrosive fluids. There is no seals in contact with the medium pumped and no valves to clog. The inner surfaces are smooth and easy to clean; fluid contacts only the tubing or tube material. Suction lift and priming can be up to 8m water column at sea level. It can handle the most shear sensitive of fluids like latex or firefighting foam with low shearing. It is capable of running dry and pumping fluids with high quantities of entrained air, such as black liquor soap. The high volumetric efficiency allows operation in metering or dosing applications where high accuracy is required. Tubing and tube materials are available for food and pharmaceutical use.

- LCD displays speed and working mode
- Keypad for operating
- Time dispense mode, set the run time, the interval time, the number of runs
- High-precision speed control
- Optional external analog signal controls speed, logic level signal controls start-stop, directions. Control signals are optically isolated.
- RS485 communication, supports MODBUS communication protocols and facilitates connectivity to a variety of control devices

- Wi-Fi communication is supported for easy wireless and remote control (Wi-Fi function is not available for US/ Europe Market).
- Circuit boards with conformal coating to achieve dust and moisture-proof
- Ultra-strong anti-electromagnetic interference feature, wide voltage design, suitable for complex power supply environments
- Plastic housing, easy to clean, strong anti-interference ability

3 Components and Connectors

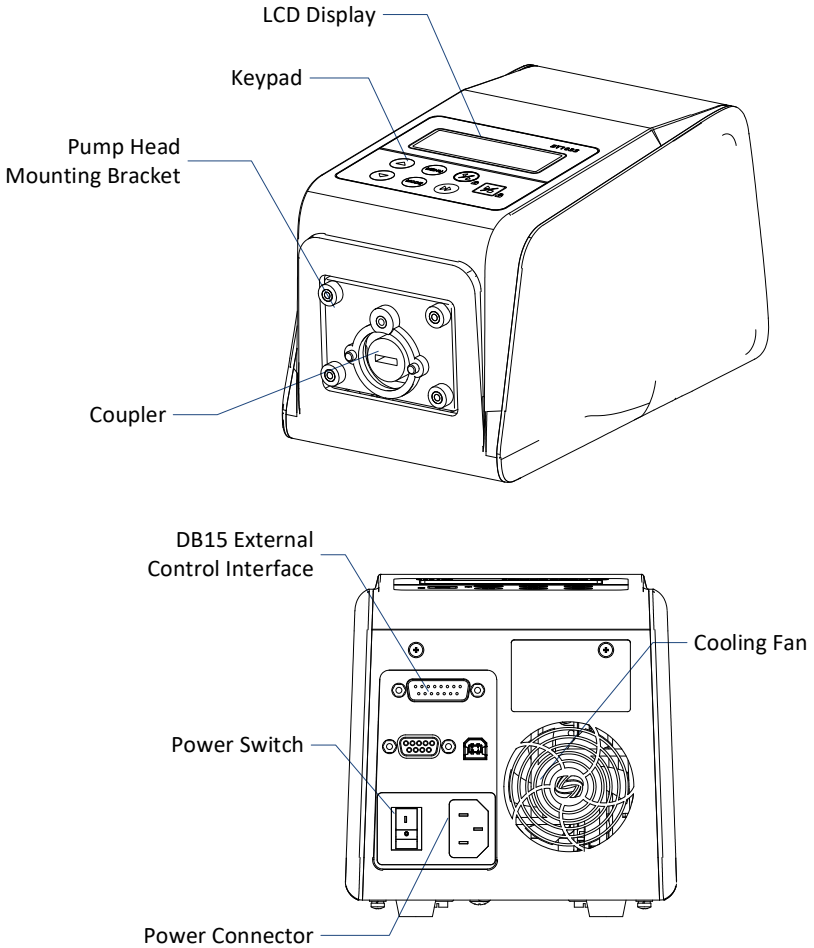

Figure 1. Components and Connectors

4 Display Panel and Operating Keypad

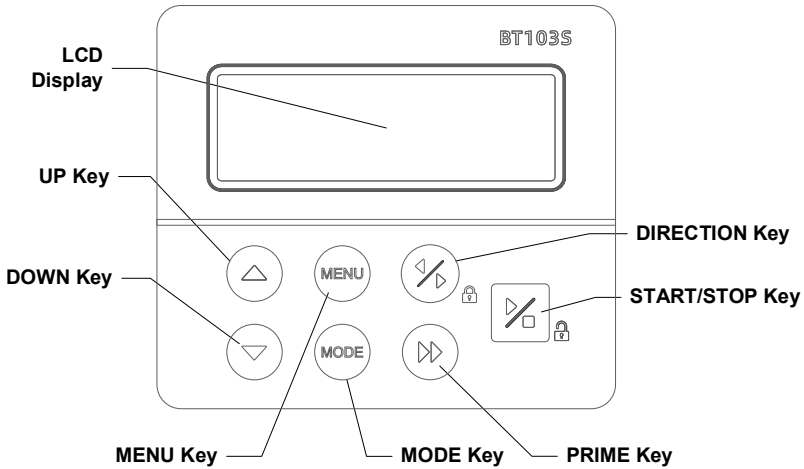





Figure 2. Display Panel

4.1 Keypad

 **UP Key.** When press it shortly, the last digit of the value will increase 1. Hold the key to increase the value quickly.

 **DOWN Key.** When press it shortly, the last digit of the value will decrease 1. Hold the key to decrease the value quickly.

 **MENU Key.** When on main screen, press the **MENU** key to enter the setting menu. When on the setting menu, press the **MENU** key to return to main screen. When the drive is running, this key is disabled.

 **MODE key.** When the drive is not running, use the **MODE** key to change the working mode: Internal Control mode, External Control mode, Time Dispense mode, Logic Level 1 control mode or Logic Level 2 Control mode.



PRIME key. Press the key to run pump at maximum

allowed speed in the direction shown on the display. Press again to return to the previous state.



DIRECTION Key. Press to key to change the drive rotating

direction, clockwise or counterclockwise.



START/STOP key. Control the start and stop of the motor.

When on the setting men, press this key to enter the submenu.

4.2 LCD Screen Display

Data entry: When the drive is not running, press the number to input desired value in the pop-up window. See the picture below.

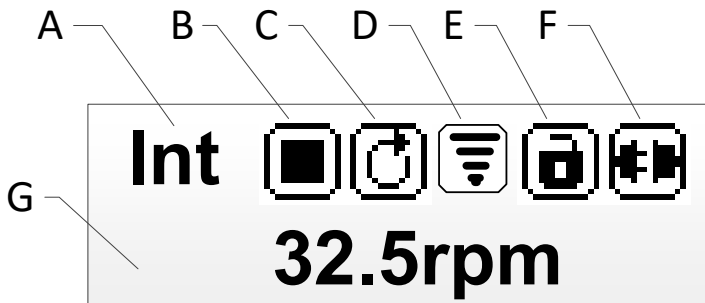

Figure 3. Display screen

4.2.1 A. Control Mode

It displays current control mode. Press **MODE** key to switch the control mode: Internal Control mode, External Control mode, Time Dispense mode, Logic Level 1 control mode or Logic Level 2 Control mode.

- Internal Control Mode: Use the keypad to operate pump. Use optional external logic signal to control start and stop.
- External Control Mode: Use external analog signal to control rotation speed. Use external logic signal to control direction,

start and stop. The keypad is disabled.

- Time Dispense Mode: Dispense fluid automatically by setting duration for each dose, time between doses and number of cycles.
- Logic Level 1 Control Mode (footswitch): Use external logic signal to control start and stop. Use the keypad to control direction and speed.
- Logic Level 2 Control Mode (footswitch and direction switch): Use external logic signal to control start, stop and direction. Use the keypad to adjust speed.

4.2.2 B. Running State

It shows current drive running state.



Figure 4. Running State

4.2.3 C. Direction State

It shows current drive direction setting.



Figure 5. Direction

4.2.4 D. Wi-Fi Signal Strength

Displays the current Wi-Fi signal strength.

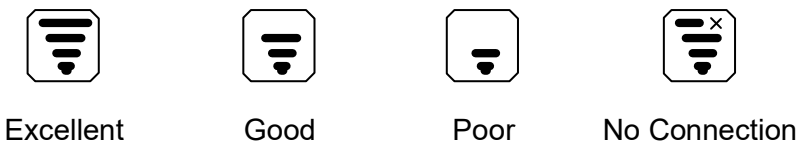

Figure 6. Wi-Fi Signal Strength

4.2.5 E. Keypad Lock Status

It shows the state of the keypad lock. When the keypad is locked, only the **START/STOP** key will work. On the main screen, press and hold the **DIRECTION** key to lock the keypad; press and hold the **START/STOP** key to unlock the keypad.



Keypad unlocked



Keypad locked

Figure 7. Keypad Lock

4.2.6 F. Communication State

It shows the current RS485 Modbus communication state.



Communication
disconnected

#1

Connected, pump
number is set to 1

Figure 8. Communication state

4.2.7 G. Rotating Speed State

It shows the current rotating speed, rpm. When the drive is running at full speed (prime), the display will be >>>>>>.

5 Parameter Settings

On the main screen, press the **MENU** key to enter the setting menu, press the **UP** or **DOWN** key to choose the parameter to adjust, press the **START/STOP** key to show the value of the parameter, then use the **UP** or **DOWN** key to adjust the value. Press the **START/STOP** key to confirm and back to the setting menu screen. To return the main screen, press and hold the **MENU** key or press the **MENU** key a few times until it goes back to the main screen.

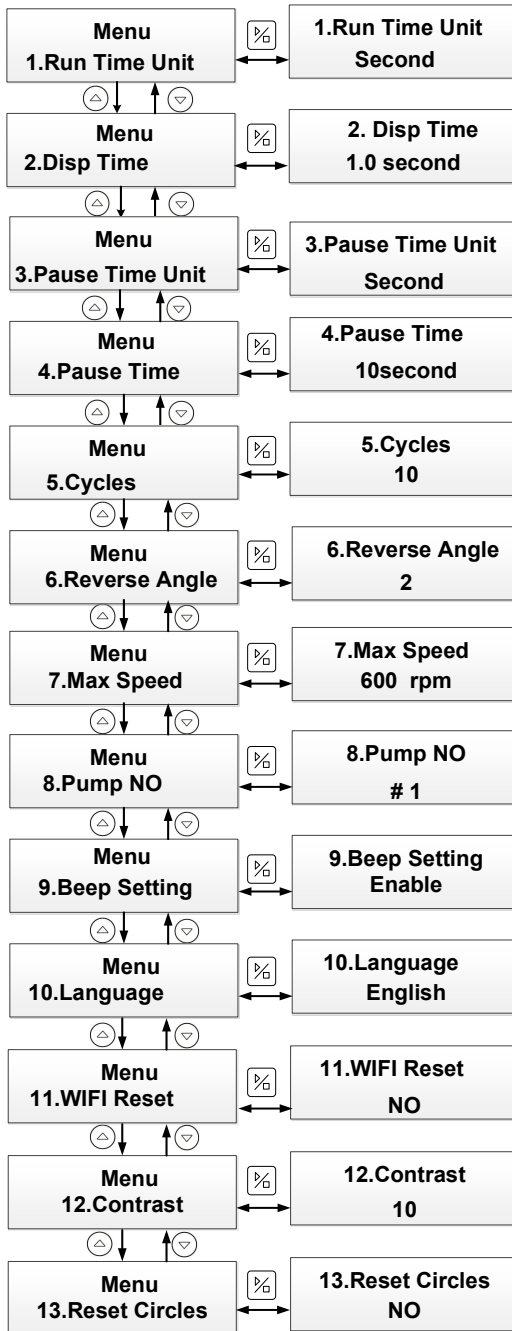

Figure 9. Parameter Setting Flow Chart

Note 1. Run Time Unit: Time unit for the dispense duration of Time Dispense mode. The unit can be in days, hours, minutes or seconds.

Note 2. Disp Time: Dispense time for Time Dispense mode. It is the dispense duration for each dose. The range is 0.1-999 seconds/minutes/hours/days.

Note 3. Pause Time Unit: Time unit for the interval time of Time Dispense mode. The unit can be in days, hours, minutes or seconds.

Note 4. Pause time for dispense mode. It is the interval time between doses when the number of cycles setting is more than 1. The range is 0.1-999 seconds/minutes/hours/days.

Note 5. Cycle: Number of cycles for Time Dispense mode. The range is 0-999 cycles. If it is set to 0, the dispense process will keep running until **START/STOP** is pressed, otherwise, pump will stop when it finishes dispensing the set number of cycles (*Figure 17*).

Note 6. Reverse Angle: To minimize the drip after a dispense, the drive can reverse direction to draw the fluid back at the end of the tubing. The reverse angle range is 0-720 degrees. When it set to 0, the anti-drip function is disabled.

Note 7. Max Speed: Maximum speed for External Control mode. It is the maximum speed that the external analog signal can control.

Note 8. Pump No: It is the pump communication address for communication mode. When the number is changed, please restart pump to apply the setting.

Note 9. Beep Setting: Set the key tone on or off.

Note 10. Language: System language setting, English or Chinese.

Note 11. WIFI Reset: Reset WIFI to link the drive to APP.

Note 12. Contrast: LCD backlight contrast setting.

Note 13. Reset hose life: after replacing the new hose, the hose life needs to be reset and the hose life will be recounted.

6 External Control Interface

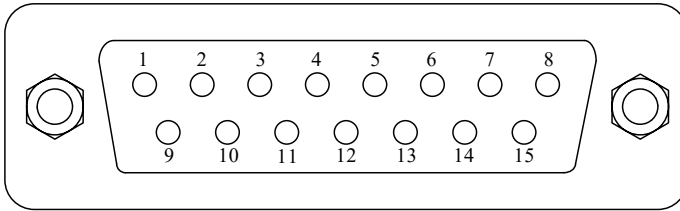

DB15	Mark	Note
1	ADC_W	Positive of external analog input
2	B	Communication interface, B pole of RS485
3	A	Communication interface, A pole of RS485
4	VCC_W	External DC power input
5		
6	CW_W	External input signal to control direction
7	PWM	Pulse output
8	COM	Ground of external power
9	AGND	Negative of analog signal input
10	+12V	Positive of internal +12V power source
11	GND	Ground of Internal power source
12	CW	Internal direction signal output
13	RS_W	External start/stop signal input terminal
14	PWM_W	External pulse signal input
15	RS	Internal start/stop signal output

7 Operation Instructions

7.1 Before Operating

- 1) Please check the packing slip to make sure nothing is wrong or damaged in the package. If there is problem, please contact the manufacturer or distributor.
- 2) Read through the instruction.

- 3) There should be more than 200 mm space for the back of the pump when it is running.

7.2 Power Connection

The voltage of the power supply should be marked on the sticker of the pump. Please make sure to use the right power source for the pump. Please plug the power cord into the IEC Power Connector on the rear of the pump and plug the opposite end of the power cord into an electrical outlet. Flip the power switch located on the rear of the pump.

7.3 Change Control Mode

Turn on the power switch. The display will show welcome message then show the main screen. Press the **MODE** key to change the working mode (*Figure 10*).

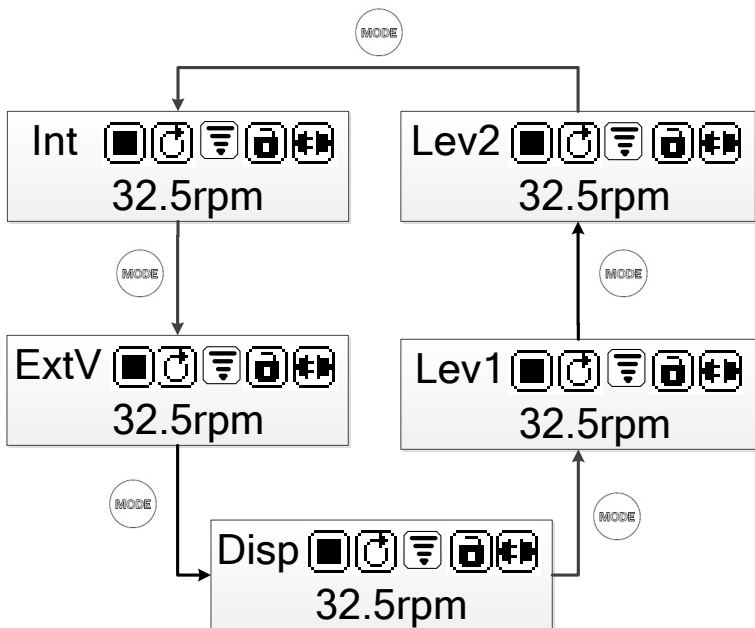

Figure 10. Change Working Mode

7.4 Internal Control Mode

Use the keypad to operate pump. Use optional external pulse signal to control start and stop.

- 1) Turn on the power switch. Pump will display the main screen.
- 2) Press **MODE** key to change the mode to Internal Control mode (Int shown on the screen).
- 3) Press **UP** or **DOWN** key to adjust the speed.
- 4) Press **DIRECTION** key to change the rotating direction.
- 5) Press **START/STOP** key to start or stop pump.
- 6) Press **PRIME** key, pump will run at maximum allowed speed.

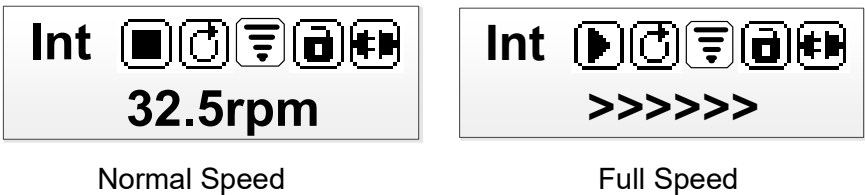

Figure 11. Normal vs Full Speed

7.5 External Control Mode

On this mode, use external logic level signal to control direction, start and stop; use external analog signal to control rotation speed. The keypad is disabled.

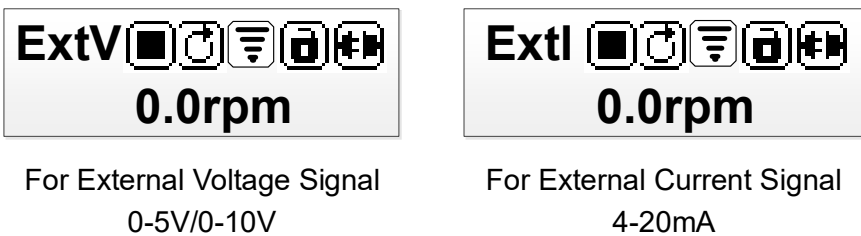

Figure 12. External Control Mode

To control pump by external signal:

- 1) Switch the power off. Wire the DB15 connector as shown on [Figure 13](#) or [Figure 14](#). Connect it to the DB15 port on the rear of the pump.

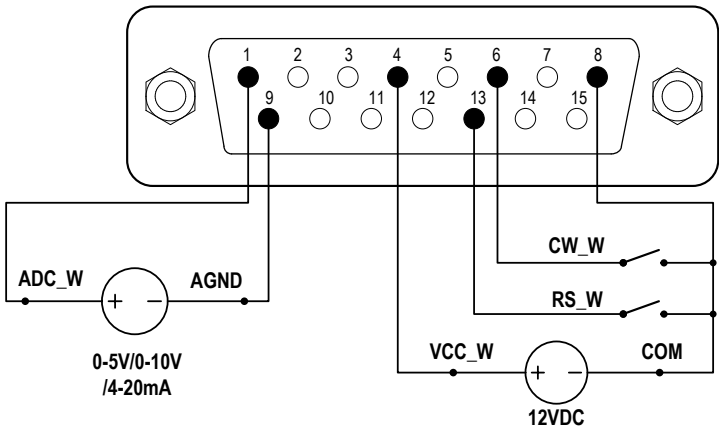

Figure 13. DB15 Wiring with External 12VDC Power Source

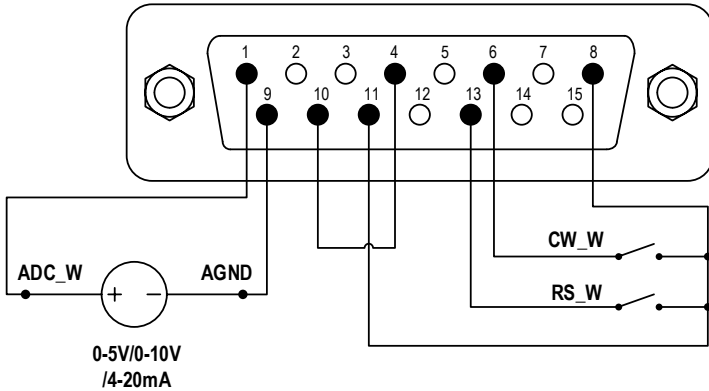

Figure 14. DB15 Wiring with Internal 12VDC Power Source

- 2) Turn on the power switch. Pump will display the main screen.
- 3) Press **MODE** key to change the mode to External Control mode (ExtV or ExtI shown on the screen).
- 4) Close the external RS_W switch, and turn on the external analog signal power source. The speed will change according to the intensity of the input signal. Open the RS_W to stop the drive.
- 5) Open CW_W switch, then pump will run in clockwise direction; close the CW_W switch, then pump will run in

counterclockwise direction.

Note: The external DC power source can be 5V or 12V. If it is 24V, 1.5K resistor is needed to protect internal circuit.

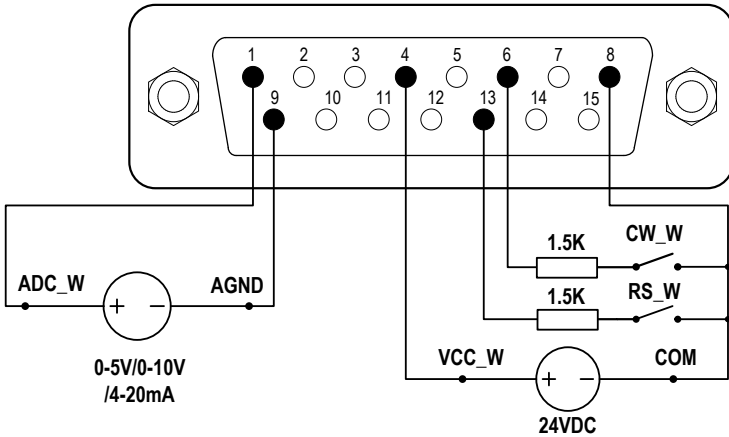

Figure 15. DB15 Wiring with External 24VDC Power Source

7.6 Time Dispense Mode

Pump will dispense fluid automatically by setting duration for each dose, pause time between doses and number of cycles. When dispensing, the display will show the dispensing time or lag time that has passed (1.2s on the figure below), and the total cycles (4 on the figure) that has dispensed.

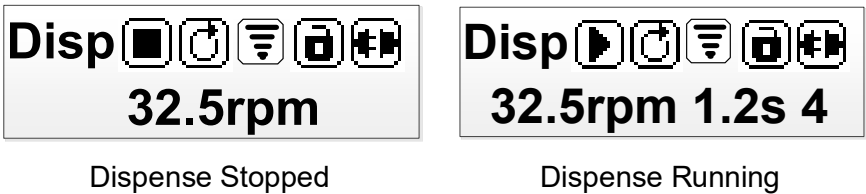

Figure 16. Time Dispense Mode

To set Time Dispense mode:

- 1) Turn on the power switch. Pump will display the main screen.
- 2) Press **MODE** key to change the mode to Time Dispense mode (Disp shown on the screen).
- 3) Press **MENU** key to enter the Setting menu.

- 4) Set time unit and duration for each dose, pause time between doses, set number of cycles.
- 5) Return to main screen.

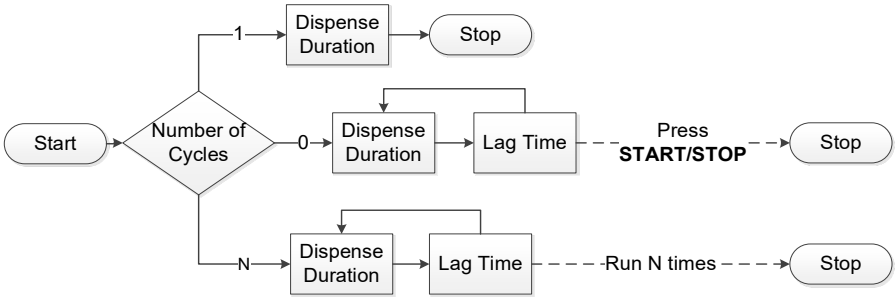

Figure 17. Dispense Cycle Setting

To run Time Dispense:

- 1) Press **DIRECTION** key to set the running direction, clockwise or counterclockwise.
- 2) Press **START/STOP** key to start dispensing.
- 3) During operating, press **START/STOP** key to stop the drive anytime when necessary.
- 4) A footswitch can be used to start/stop pump.

7.7 Logic Level 1 Control Mode (footswitch)

Use external logic level signal to control start and stop. Use the keypad to control direction and speed.



Figure 18. Logic Level 1 Control Mode

- 1) Switch the power off. Wire the DB15 connector as shown on [Figure 19](#) or [Figure 20](#), and connect it to the DB15 port on the rear of the pump.

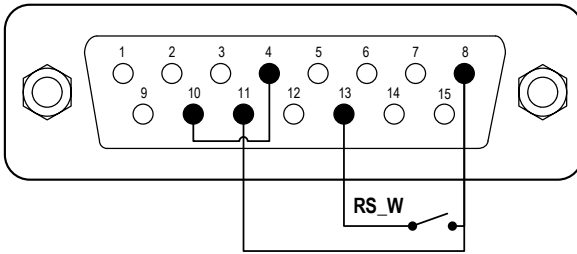

Figure 19. Logic Level 1 Control with Internal 12V Power Source

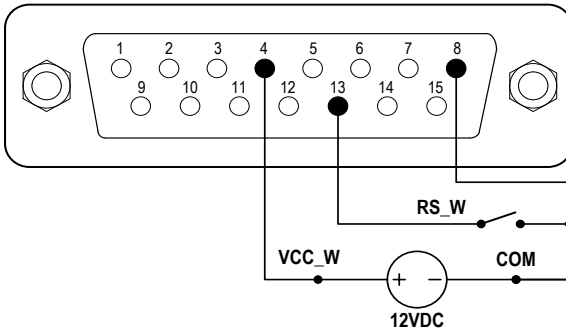

Figure 20. Logic Level 1 Control with External 12V Power Source

- 2) Turn on the power switch. Pump will display the main screen.
- 3) Press **MODE** key to change the mode to Logic Level 1 control mode (shows lev1 on the screen).
- 4) Press **UP** or **DOWN** key to adjust the speed.
- 5) Press **DIRECTION** key to change the rotating direction.
- 6) When the switch is closed, the drive will start running; when the switch is open, the drive will stop.

Note: Use this mode to work with a TIME CONTROLLER.

7.8 Logic Level 2 Control Mode (footswitch and direction switch)

Use external logic level signal to control start, stop and direction.
Use the keypad to control speed.

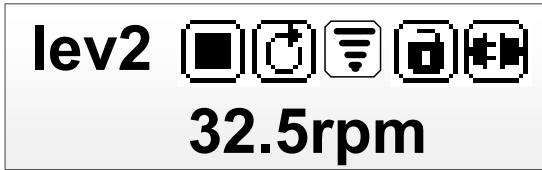

Figure 21. Logic Level 2 Control Mode

- 1) Switch the power off. Wire the DB15 connector as shown on [Figure 22](#) or [Figure 23](#), and connect it to the DB15 port on the rear of the pump.

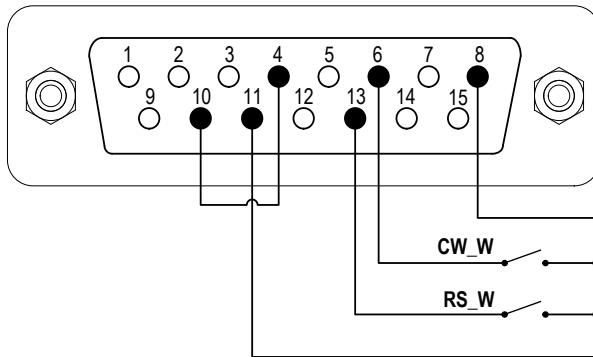

Figure 22. Logic Level 2 Control with Internal 12V Power Source

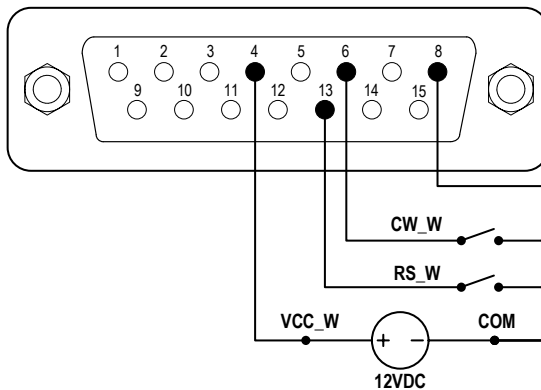

Figure 23. Logic Level 2 Control with External 12V Power Source

- 2) Turn on the power switch. Pump will display the main screen.
- 3) Press **MODE** key to change the mode to Logic Level 2 control mode (shows lev2 on the screen).
- 4) Press **UP** or **DOWN** key to adjust the speed.
- 5) When the switch RS_W is closed, the drive will be running at the set speed; when the switch RS_W is open, the drive will stop.
- 6) When the switch CW_W is open, the drive will be running in clockwise direction. When the switch CW_W is closed, the drive will be running in counterclockwise direction.

7.9 Communication Mode

The RS485 interface supports standard MODBUS protocol. Pump can communicate with external device via the communication port. Please refer to the [Communication Instruction manual](#) for the parameters and supported commands.

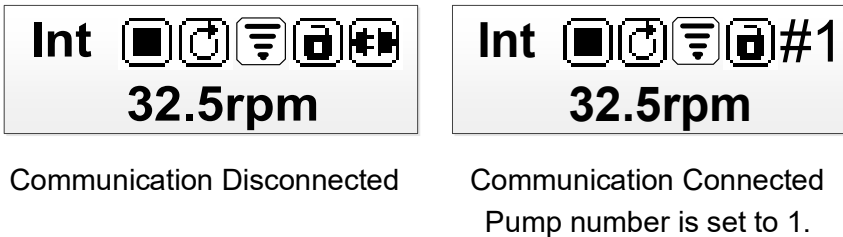

Figure 24. Communication Mode

- 1) When the power is off, wire the DB15 connector as shown on [Figure 25](#), and connect it to the DB15 port on the rear of the pump. External DC power source is recommend to avoid electrical interference.

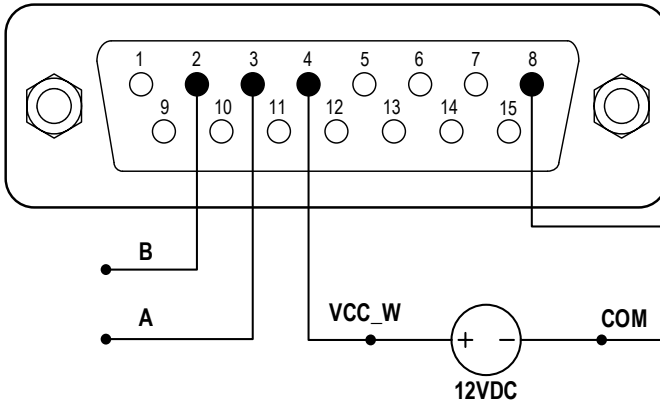

Figure 25. RS485 MODBUS Wiring

- 2) Turn on the power switch. Pump will display the main screen.
- 3) Press **MODE** key to change the mode to Internal Control mode or Time Dispense mode.
- 4) Control pump with communication interface.
- 5) Press the **START/STOP** key to stop the drive anytime.

7.10 Set Speed

On the main screen, the speed resolution is 0.1 rpm when the speed is between 0.1 and 100 rpm; the speed resolution is 1 rpm when the speed is above 100 rpm. The speed can be set by pressing the **UP** or **DOWN** key. Press the **UP** or **DOWN** key shortly, the last digit of the value will change 1. Hold the **UP** or **DOWN** key to change the speed continuously and rapidly.

Hold the **PRIME** key, then press the **UP** key to set the speed to maximum directly; hold the **PRIME** key, then press the **DOWN** key to set the speed to minimum (0.1 rpm) directly.

7.11 Wi-Fi Network Setting

When the device is powered on, the display shows that Wi-Fi is not connected (Wi-Fi function is not available for US/ Europe Market).

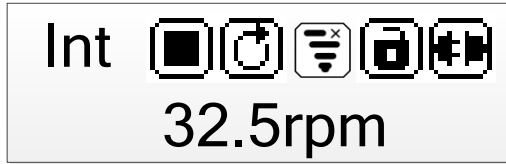

Figure 26. Wi-Fi Disconnected

To set up Wi-Fi connection

- 1) Connect your smartphone/pad to the current Wi-Fi network and log in to your cloud control APP account.
- 2) In the upper right corner of the cloud control home page, click the "+Add Device" button, select "Wi-Fi Configuration" to add devices, app will automatically read the current Wi-Fi, manually enter the Wi-Fi password after clicking on the "Confirm" button, wait about 20 seconds, you will see the added device.

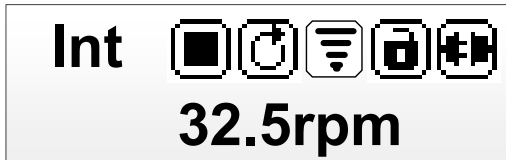

Figure 27. Wi-Fi connected

8 Maintenance

8.1 Warranty

The product comes with one-year labor and parts warranty. The limited warranty does not cover any damage that is caused by improper usage and handling.

8.2 Regular Maintenance

- 1) Always check the tubing and connections to make sure there is no leakage.
- 2) Do not cover the fan on the rear of the pump.
- 3) Do not use water to wash the pump. Keep pump head dry.

- 4) Do not use chemical solvents to clean pump and pump head.

8.3 Malfunction Solutions

No	Malfunction	Description	Solution
1	Hardware	No display	<ol style="list-style-type: none"> 1. Check the power cord 2. Check the fuse. If it was blown, replace it with a 0.5A slow-blow fuse 3. Check the internal power cord connection inside the pump.
2	Hardware	Motor does not work	<ol style="list-style-type: none"> 1. Check the indicator of the driver board. 2. Check the wire connection between the motor and the driver board. 3. Check the wire connection between the driver and the main board. 4. Check the power voltage for the pump.
3	Hardware	Motor only runs in one direction	Check the connection between the drive board and the main control board.
4	Hardware	Keypad does not work	<ol style="list-style-type: none"> 1. Check the wire connection between keypad and the main board. 2. Check if the key is broken.
5	Hardware	External control does not work	<ol style="list-style-type: none"> 1. Check the wiring of the connector. 2. Check if the external control power voltage is provided. 3. Check the connections of the external control board.
6	Hardware	RS485 com does not	<ol style="list-style-type: none"> 1. Check the wiring of the connector. 2. Check if the external control

Golander BT103S Manual

		work	power voltage is provided. 3. Check the connections of the communication board.
7	Hardware	Noisy when running	Check the screws and level on pump head to make sure they are secure.
9	Software	External control does not work	Check if pump is on External Control Mode.
10	Software	RS485 does not work right	1. Check if the display shows the communication is ready. 2. Reset the address of the pump. 3. Check whether on the bus there are two pumps using the same address



If the problem cannot be solved, please contact the manufacturer or distributor.

9 Dimensions

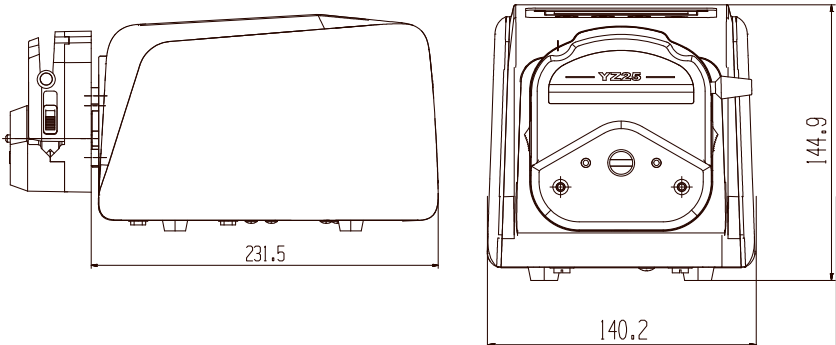
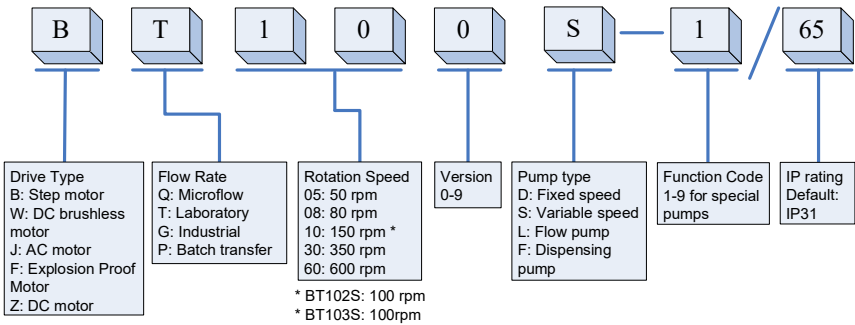

Figure 28. Dimensions (mm)

10 Naming Rule



11 Specifications

Suitable pump heads	YZ15, YZ25, YT15, YT25, DG1, DG2, DT10-18, DT10-28
Speed resolution	0.1-100 rpm, 0.1 rpm resolution; 100-600 rpm, 1 rpm resolution
Speed accuracy	0.5%
Power supply	AC 90-240V, 50/60Hz
Power consumption	40W
External logic control signal	5V, 12V (standard), 24V (optional)
External analog control signal	0-5V, 0-10V, 4-20mA
Communication interface	RS485 MODBUS, Wi-Fi
Operating condition	Temperature 0~40°C Relative humidity <80%
IP grade	IP31
Display	132x32 LCD
Dimensions (LxWxH)	232x140x145mm
Weight	2.9 kg

Golander LLC

4405 International Blvd
Ste B117, Norcross, GA 30093
USA

Tel: +1 678-587-8806

info@golanderpump.com

www.golanderpump.com

Golander GmbH

Dechant-Heimbach-Str. 29
53177 Bonn
Germany

Tel: +49 228 50446952

info@golander.de

www.golander.de