

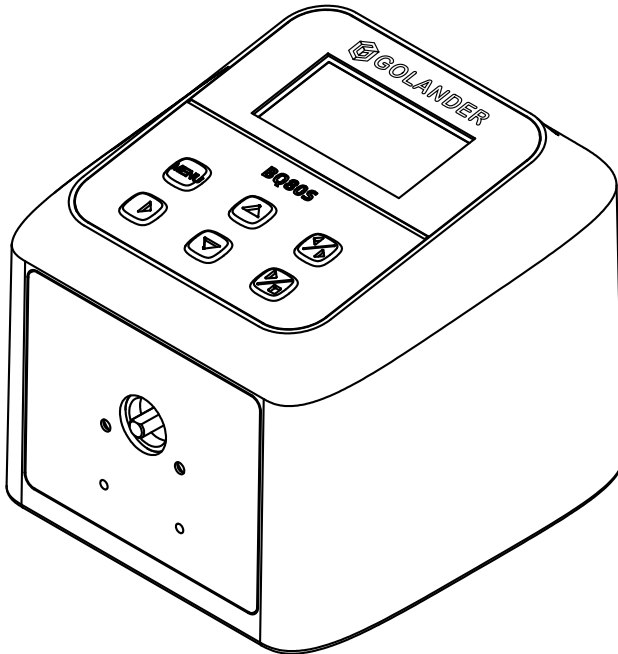

**BQ80S V2**

**Variable-Speed Peristaltic Pump**

**Operating Manual**



# Contents

Safety Precautions .....	1
1 Description .....	6
2 Functions and Features.....	6
3 Components and Connectors.....	7
4 Display Panel and Operating Keypads.....	8
4.1 Keypad .....	8
4.2 LCD Screen Display.....	9
5 Parameter Settings.....	11
6 System Advanced Parameter Settings.....	13
7 External Control Interface.....	16
8 Operating Instructions .....	16
8.1 Before Operation .....	16
8.2 Power Connection .....	17
8.3 Mode Change.....	17
8.4 Internal Control Mode.....	17
8.5 External Control Mode .....	18
8.6 Time Dispense Mode .....	20
8.7 Logic Level 1 Control Mode (footswitch).....	21
8.8 Logic Level 2 Control Mode (footswitch and direction switch).....	22
8.9 Communication Mode .....	24
8.10 Speed Setting.....	25
9 Maintenance .....	25
9.1 Warranty.....	25
9.2 Regular Maintenance .....	26
9.3 Malfunction Solutions .....	26
10 Dimensions.....	27
11 Naming Rule .....	28
12 Specifications .....	28

## Safety Precautions



### Danger

- Use the correct voltage indicated on the rating plate label of the pump to avoid any damage.
- Do not make any unauthorized dismantling, changes or modifications to the pump which could result in malfunctions or even potential accidents.
- Turn off the pump drive before installing or removing tubing, attempting any maintenance, cleaning or repair of the drive, connecting or disconnecting external control devices or a communication interface. Fingers or loose clothing could get caught in the drive mechanism.



### Warning

- Ensure no chemical reactions occur between the handled fluid with the material of the pump head and tubing before use.
- Tubing should be checked regularly to avoid breakage. Tubing breakage may result in fluid being sprayed from the pump. Use appropriate measures to protect the operator and equipment. The operator is solely liable for damages resulting from tubing breakage, particularly the leakage of toxic or valuable liquids.
- The pump is provided with a grounded plug which must be well grounded at all times.
- This device is not designed for nor intended for usage in patient connected applications, including but not limited to medical and dental use.
- Observe all other applicable regulations concerning working safety, operational safety, environmental protection and relevant local regulations.

## **(DE) SICHERHEITSHINWEISE**



### **Gefahr**

- Verwenden Sie die richtige Spannung, die auf dem Typenschild der Pumpe angegeben ist, um Schäden zu vermeiden.
- Nehmen Sie keine unbefugten Demontagen, Änderungen oder Modifikationen an der Pumpe vor, die zu Fehlfunktionen oder sogar zu Unfällen führen könnten.
- Schalten Sie den Pumpenantrieb aus, bevor Sie Schläuche ein- oder ausbauen, Wartungs-, Reinigungs- oder Reparaturarbeiten am Antrieb vornehmen oder externe Steuergeräte oder eine Kommunikationsschnittstelle anschließen oder trennen. Finger oder lose Kleidungsstücke können sich im Antriebsmechanismus verfangen.



### **Warnung**

- Vergewissern Sie sich vor der Verwendung, dass keine chemischen Reaktionen zwischen dem Fördermedium und dem Material des Pumpenkopfs und der Schläuche auftreten können.
- Die Schläuche sollten regelmäßig überprüft werden, um Brüche zu vermeiden. Ein Schlauchbruch kann dazu führen, dass Flüssigkeit aus der Pumpe spritzt. Ergreifen Sie geeignete Maßnahmen zum Schutz des Bedieners und der Ausrüstung. Der Betreiber haftet allein für Schäden, die durch einen Schlauchbruch entstehen, insbesondere für das Austreten von giftigen oder wertvollen Flüssigkeiten.
- Die Pumpe ist mit einem geerdeten Stecker ausgestattet, der stets korrekt an eine abgesicherte Netzsteckdose angeschlossen sein muss. Dieses Gerät ist nicht für Anwendungen ausgelegt oder vorgesehen, die im Zusammenhang mit der Behandlung von Patienten stehen. Medizinische bzw. zahnmedizinische Anwendungen sind nicht bestimmungsgemäß.
- Beachten Sie alle anderen geltenden Vorschriften zur Arbeitssicherheit, zur Betriebssicherheit, zum Umweltschutz sowie die einschlägigen örtlichen Vorschriften.

## (FR) CONSIGNES DE SÉCURITÉ



### **Danger**

- Utilisez la tension correcte indiquée sur la plaque signalétique de la pompe afin d'éviter tout dommage.
- Ne procédez pas à des démontages, changements ou modifications non autorisés de la pompe qui pourraient entraîner des dysfonctionnements, voire des accidents.
- Mettez l'entraînement de la pompe hors tension avant d'installer ou de retirer des tuyaux, d'effectuer des travaux d'entretien, de nettoyage ou de réparation sur l'entraînement ou de connecter ou déconnecter des dispositifs de commande externes ou une interface de communication. Des doigts ou des vêtements lâches pourraient se prendre dans le mécanisme d'entraînement.



### **Avertissement**

- Avant toute utilisation, assurez-vous qu'il n'y a pas de réaction chimique entre le liquide pompé et le matériau de la tête de pompe et des tubes.
- Les tuyaux doivent être contrôlés régulièrement pour éviter les ruptures. Une rupture de tuyau peut entraîner des projections de liquide hors de la pompe. Prenez les mesures appropriées pour protéger l'opérateur et l'équipement. L'opérateur est seul responsable des dommages causés par une rupture de tuyau, notamment en cas de fuite de liquides toxiques ou précieux.
- La pompe est équipée d'une fiche de mise à la terre qui doit toujours être bien reliée à la terre.
- Cet appareil n'est pas conçu ni prévu pour être utilisé en présence de patients, y compris, mais sans s'y limiter, dans le cadre d'applications médicales et dentaires.
- Respectez toutes les autres réglementations applicables en matière de sécurité du travail, de sécurité d'exploitation, de protection de l'environnement.

## (ES) INSTRUCCIONES DE SEGURIDAD



### **Peligro**

- Utilice la tensión correcta indicada en la placa de características de la bomba para evitar daños.
- No realice ningún desmontaje, cambio o modificación no autorizada en la bomba que pueda provocar un mal funcionamiento o incluso accidentes.
- Desconecte el accionamiento de la bomba antes de instalar o retirar las mangueras, realizar trabajos de mantenimiento, limpieza o reparación en el accionamiento o conectar o desconectar dispositivos de control externos o una interfaz de comunicación. Los dedos o la ropa suelta podrían quedar atrapados en el mecanismo de accionamiento.



### **Advertencia**

- Antes de usarla, asegúrese de que no hay reacciones químicas entre el medio bombeado y el material de la cabeza de la bomba y las mangueras.
- Las mangueras deben ser revisadas regularmente para evitar roturas. La rotura de una manguera puede hacer que salga líquido de la bomba. Tome las medidas adecuadas para proteger al operador y al equipo. El operador es el único responsable de los daños causados por la rotura de una manguera, especialmente por la fuga de líquidos tóxicos o valiosos.
- La bomba está equipada con un enchufe con toma de tierra que debe estar siempre bien conectado a tierra.
- Este aparato no está diseñado ni pensado para su uso en relación con los pacientes, incluyendo pero sin limitarse a las aplicaciones médicas y dentales.
- Respetar todas las demás normas aplicables en materia de seguridad laboral, seguridad operativa y protección del medio ambiente.

## (IT) ISTRUZIONI DI SICUREZZA



### Pericolo

- Usare la tensione corretta indicata sull'etichetta della targhetta della pompa per evitare qualsiasi danno.
- Non eseguire smontaggi, cambiamenti o modifiche non autorizzati alla pompa che potrebbero causare malfunzionamenti o addirittura potenziali incidenti.
- Spegnere l'azionamento della pompa prima d'installare o rimuovere tubi, tentare qualsiasi manutenzione, pulizia o riparazione dell'azionamento, collegare o scollegare dispositivi di controllo esterni o un'interfaccia di comunicazione. Dita o indumenti larghi potrebbero rimanere impigliati nel meccanismo di azionamento.



### Attenzione

- Assicurarsi che non si verifichino reazioni chimiche tra il fluido trattato e il materiale della testa della pompa e dei tubi prima dell'uso.
- I tubi devono essere controllati regolarmente per evitare rotture. La rottura del tubo può provocare spruzzi di fluido dalla pompa. Utilizzare misure appropriate per proteggere l'operatore e l'attrezzatura. L'operatore è l'unico responsabile dei danni derivanti dalla rottura dei tubi, in particolare della fuoriuscita di liquidi tossici o preziosi.
- La pompa è dotata di una spina con messa a terra che deve essere sempre ben collegata a terra.
- Questo dispositivo non è progettato né destinato all'uso in applicazioni collegate al paziente, incluso ma non limitato all'uso medico e dentistico.
- Osservare tutte le altre norme applicabili riguardanti la sicurezza sul lavoro, la sicurezza operativa, la protezione dell'ambiente e le norme locali pertinenti.

# 1 Description

BQ80S V2 variable-speed peristaltic pump provides not only basic functions such as start/stop, reversible direction and adjustable speed, but also the Time Dispense Mode and Anti-Drip function. With the MODBUS RS485 interface, the pump is easy to communicate with external devices, such as PC, HMI or PLC. Flow rate range 0.004-77 mL/min, working speed 0.1-80 rpm.

## 2 Functions and Features

Peristaltic pumps can handle fluid that is particularly abrasive, corrosive or viscous. There are no seals in contact with the medium pumped and no valves to clog. The inner surfaces are smooth and easy to clean. The fluid contacts only the tubing or tube material. It can handle the most shear sensitive of fluids like latex or firefighting foam with low shearing. It is capable of running dry and pumping fluids with high quantities of entrained air, such as black liquor soap. The high volumetric efficiency allows operation in metering or dosing applications where high accuracy is required. Tubing and tube materials are available for food and pharmaceutical use.

- 128 x 32 dot matrix LCD, simple and intuitive parameter setting and status display.
- Membrane keypad.
- Supports blocking alarm.
- Supports acceleration start and deceleration stop functions.
- Reversible direction, start/stop control and adjustable speed.
- Timing function and slow start/stop function for smooth liquid transfer.
- An external logic level signal can control start/stop, direction and dispense functions; an external analogue signal can adjust the rotating speed. The signal is optically isolated.
- External control signal supports wide voltage input from 5 to 24 V.
- External speed control signal type (voltage or current) can be switched via the control panel.
- The RS485 MODBUS interface allows easy communication with external devices.



- Circuit board with conformal coating to achieve dust and moisture resistance.
- Anti-electromagnetic interference feature; wide input voltage range for complex power environment.
- ABS engineering plastic housing, streamlined design

### 3 Components and Connectors

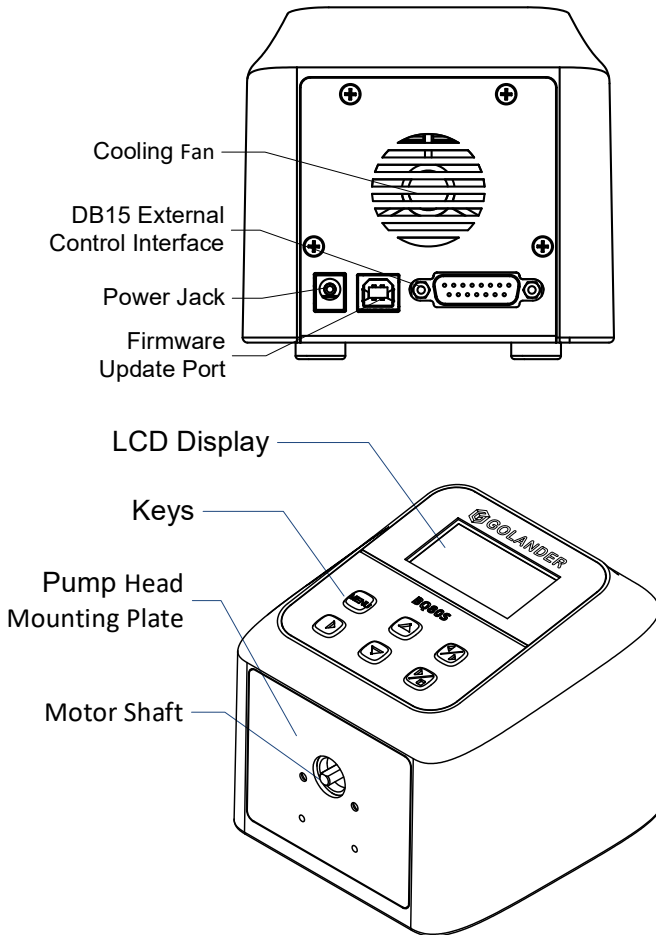

Figure 1. Components and Connectors

## 4 Display Panel and Operating Keypads

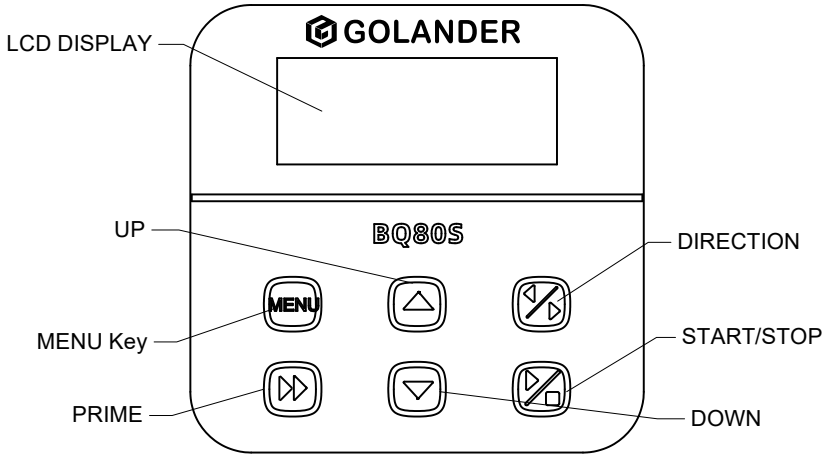

Figure 2. Display Panel

### 4.1 Keypad



**UP Key.** When pressed shortly, the last digit of the value will increase by 1. Hold the key to increase the value quickly.



**DOWN Key.** When pressed shortly, the last digit of the value will decrease by 1. Hold the key to decrease the value quickly.



**MENU Key.** When on the main screen, press the **MENU** key to enter the setting menu. When on the setting menu, press the **MENU** key to switch between the different menus. Press and hold it to return to the main screen. When the drive is running, this key is disabled.



**PRIME key.** Press the key to run the pump at the maximum allowed speed in the direction shown on the display. Press again to return to the previous state.



**DIRECTION Key.** Press to key to change the drive rotating direction, clockwise or counterclockwise.



**START/STOP key.** Press to start or stop the drive.

## 4.2 LCD Screen Display

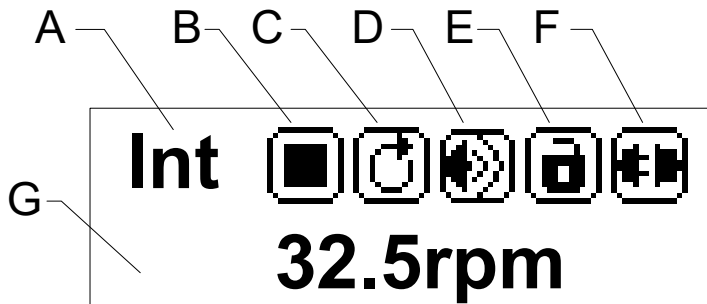

Figure 3. Display screen

### 4.2.1 A. Control Mode

It displays the current control mode. Press the **MENU** key, the display will show “Run Mode”, press the START/STOP key to enter the setting of the control mode, then use UP/DOWN key to change the control mode: Internal Control Mode, External Control Mode, Time Dispense Mode, Logic Level 1 Control Mode or Logic Level 2 Control Mode.

- Internal Control Mode: Use the keypad to operate the pump. Use an optional external pulse signal to control the start and stop.
- External Control Mode: Use an external analogue signal to control rotation speed. Use external logic level signal to control direction, start and stop. The keypad is disabled.
- Time Dispense Mode: Dispense fluid automatically by setting duration for each dose, the time between doses and the number of cycles.
- Logic Level 1 Control Mode (footswitch): Use an external logic-level signal to control the start and stop. Use the keypad to control direction and speed.
- Logic Level 2 Control Mode (footswitch and direction switch): Use external logic level signal to control start, stop and direction. Use the keypad to adjust speed.

### 4.2.2 B. Running State

It shows the current drive running state.



Figure 4. Running State

### 4.2.3 C. Direction State

It shows the current drive direction setting.



Figure 5. Direction

### 4.2.4 Wi-Fi Signal Strength

When Wi-Fi is disabled in **System Advanced Parameter Settings**, it shows the state of the key tone, on or off.



When Wi-Fi is enabled, it shows the Wi-Fi signal strength.

Note: Wi-Fi function is not available for US/European markets.

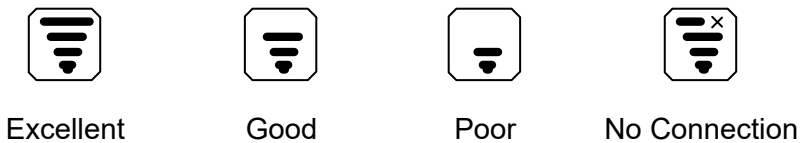

Figure 6. Key Tone State / Wi-Fi Signal Strength

### 4.2.5 E. Keypad Lock State

It shows the state of the keypad lock. When the keypad is locked, only the **START/STOP** key will work. On the main screen, press and hold the

**DIRECTION** key then release to lock the keypad; press and hold the **DIRECTION** key then release to unlock the keypad.



Keypad unlocked



Keypad locked

*Figure 7. Keypad Lock*

#### 4.2.6 F. Communication State

It shows the current RS485 communication state.



Communication  
disconnected

#1

Connected, pump  
number is set to 1

*Figure 8. Communication state*

#### 4.2.7 G. Rotating Speed State

It shows the current rotating speed, rpm. When press the “PRIME: key, the drive is running at full speed, the display will show “FULL”.

## 5 Parameter Settings

On the main screen, press the **MENU** key to enter the setting menu, press the **UP** or **DOWN** key to choose the parameter to adjust, press the **START/STOP** key to show the value of the parameter, then use the **UP** or **DOWN** key to adjust the value. Press the **START/STOP** key to confirm and back to the setting menu screen. To return the main screen, press and hold the **MENU** key or press the **MENU** key a few times until it goes back to the main screen.

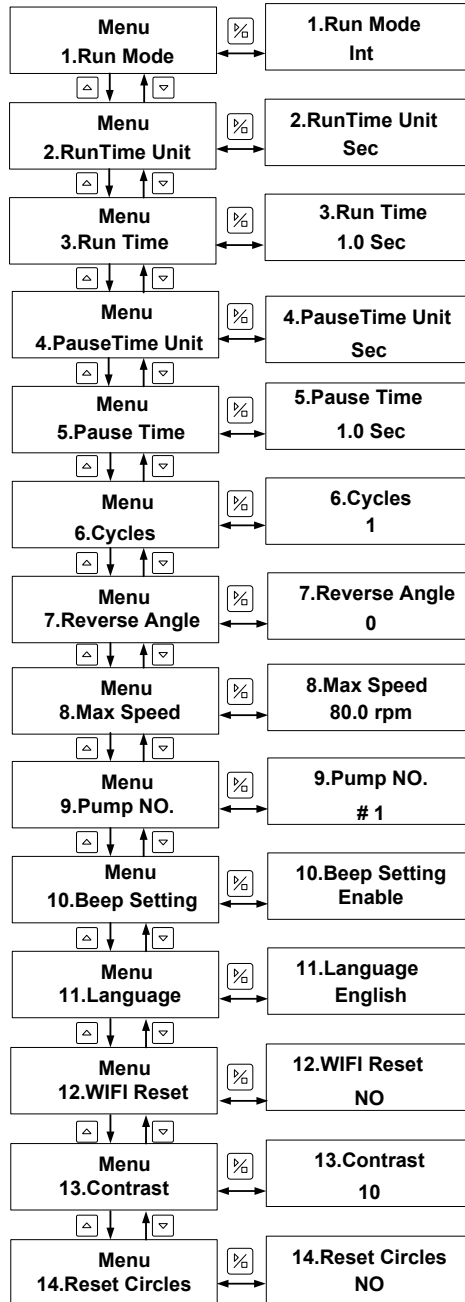











Figure 9. Parameter Setting Flow Chart

- 1. RunTime Unit: Time unit for the dispense duration of Time Dispense mode. The unit can be in days, hours, minutes or seconds.
- 2. Run Time: Dispense time for Time Dispense mode. It is the dispense duration for each dose. The range is 0.1-999 seconds/minutes/hours/days.
- 3. PauseTime Unit: Time unit for the interval time of Time Dispense mode. The unit can be in days, hours, minutes or seconds.
- 4. Pause Time: Pause time for dispense mode. It is the lag time between doses when the number of cycles set is more than 1. The range is 0.1-999 seconds/minutes/hours/days.
- 5. Cycles: Number of cycles for dispense mode. The range is 0-999 cycles. When it is set to 0, the dispensing process will keep running until **START/STOP** is pressed. When it is set to the other value, the pump will stop when the set number of dispensing cycles are completed (*Figure 17*).
- 6. Reverse Angle: To minimize the drip after a dispense, the drive can reverse direction to draw the fluid back at the end of the tubing. The reverse angle range is 0-720 degrees. When it is set to 0, the anti-drip function is disabled.
- 7. Max Speed: Maximum speed for the External Control Mode. It is the maximum speed that the external analogue signal can control.
- 8. Pump No: It is the pump communication address for the communication mode. A restart of the drive is required for this to take effect.
- 9. Beep Setting: Set the key tone on or off.
- 10. Language: System language setting, English or Chinese.
- 11. Wifi reset (ignore this setting).
- 12. Contrast: LCD backlight contrast setting.
- 13. Reset Circles: Recount tubing life after a tubing is installed or replaced.

## 6 System Advanced Parameter Settings

In the main interface, press  +  key to enter the system parameter setting interface. In this interface, press   key for advanced parameter

selection, press  key to enter the submenu, press   key to adjust parameters. To return to the previous menu, press . To return to the main interface, press  key.

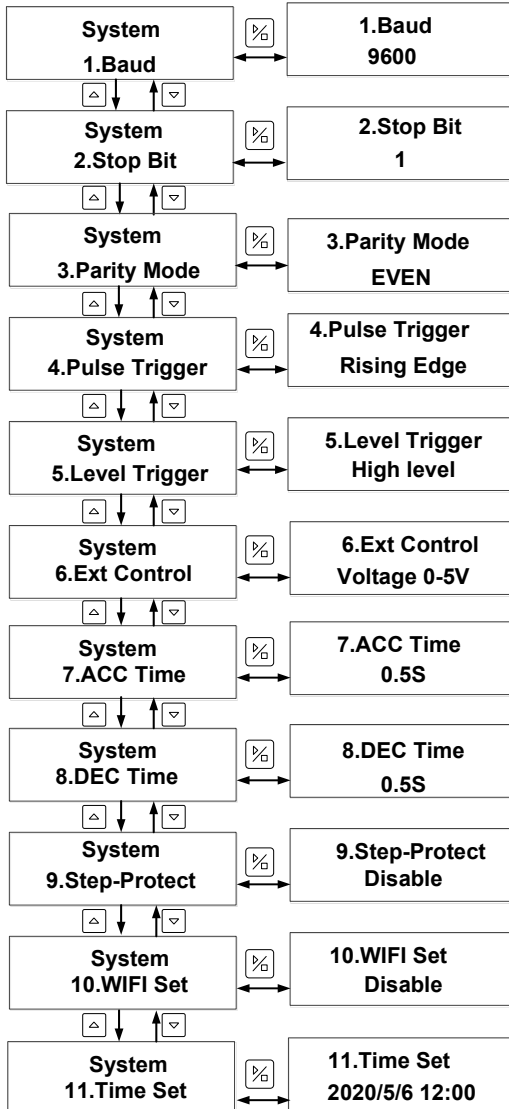



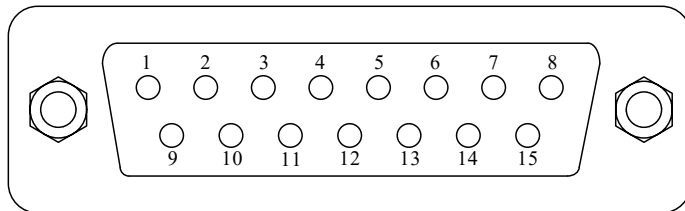

Figure 10 System advanced parameter setting flow chart



- 1. Baud: In the communication mode, set the baud to 4800, 9600, 19200, 38400 (the default is 9600).
- 2. Stop Bit: In the communication mode, set the size of the stop bit, which can be set to 1 and 2 (the default is 1).
- 3. Parity Mode: In the communication mode, set the parity type, which can be set as odd parity, even parity and none parity (the default is even parity).
- 4. Pulse Trigger: In Internal Control or Time Dispense mode, set the pulse trigger type of external control start / stop signal of the driver, which can be set as rising edge trigger and falling edge trigger (the default is rising edge trigger).
- 5. Level trigger mode: in External Control or Level mode, set the level trigger type when the driver is controlled externally, which can be set as high-level trigger and low-level trigger (the default is high-level trigger).
- 6. External Control mode: In the External Control mode, set the parameter type of analog signal to control the driver speed, which can be set to voltage mode 0-5V, voltage mode 0-10V, and current mode 4-20mA (the driver speed will change linearly with the change of external control analog signal).
- 7. Acceleration time: Set the acceleration time when the drive is started and running. The unit is seconds (the default value is 0.5 seconds).
- 8. Deceleration time: Set the deceleration time when the drive stops running. The unit is seconds (the default value is 0.5 seconds).
- 9. Step-Protect: The setting of step protection is off by default (WIFI version has this function).
- 10. WIFI setting: The WIFI switch of the driver is off by default (WIFI version has this function).
- 11. Time setting: Set the current date and time. Press  to change the set parameters, press   to adjust the time, and press  to save and exit.

## 7 External Control Interface



DB15	Mark	Note
1	ADC_W	Positive of external analogue input
2	B	Communication interface, B pole of
3	A	Communication interface, A pole of
4	VCC_W	External voltage input terminal
5	-	-
6	CW_W	External input signal to control the
7	PWM	Pulse output
8	COM	Ground of external power
9	AGND	Negative of analogue signal input
10	+12V	Positive of internal +12V power
11	GND	Ground of Internal power source
12	CW	Internal direction signal output
13	RS_W	External start/stop signal input
14	-	-
15	-	-

## 8 Operating Instructions

### 8.1 Before Operation

- 1) Please check the packing slip to ensure all parts are included and intact in the package. If there is a problem, please contact the manufacturer or distributor.
- 2) Read through the instruction.
- 3) A minimum of 200 mm space from the back of the pump should be

maintained when it is in operation.

## 8.2 Power Connection

The voltage of the power supply should match with what is indicated on the rating plate label of the pump. Please plug the 24V DC power to the connector on the rear of the pump.

## 8.3 Mode Change

Power up the pump. The display will show a welcome message then the main screen. Press the **MENU** key, the screen will show “Run Mode”, press the **START/STOP** key enter the setting for the working mode, then use the **UP** or **DOWN** key to change the working mode (*Figure 11*).

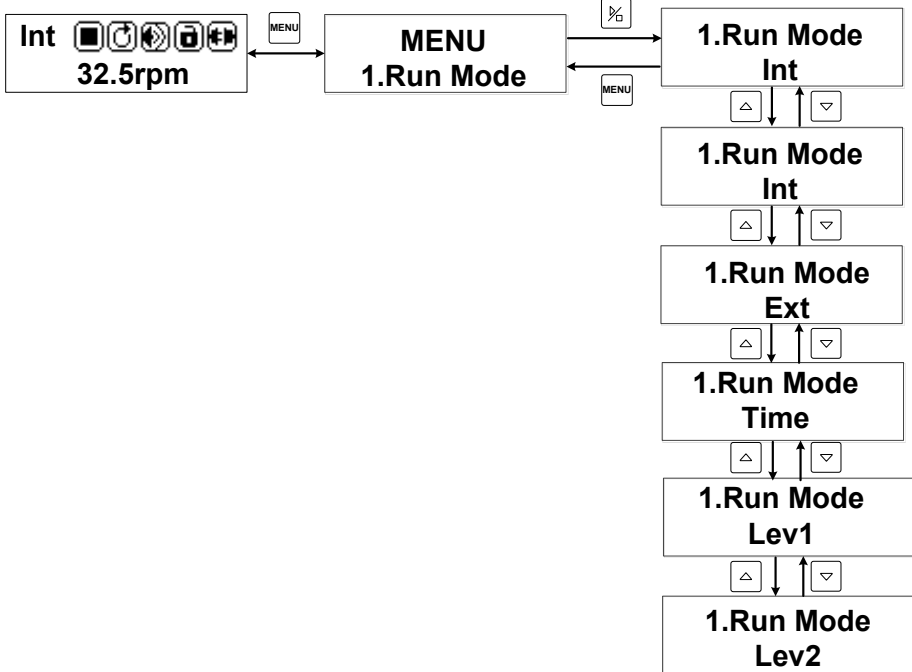
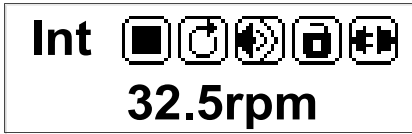

Figure 11. Change Working Mode

## 8.4 Internal Control Mode

Use the keypad to operate the pump. Use an optional external pulse signal to control the start/stop.

- 1) Power on the drive. The pump will display the main screen.
- 2) Use the **MENU** to change the mode to Internal Control mode (Int shown on the screen).
- 3) Press the **UP** or **DOWN** key to adjust the speed.
- 4) Press the **DIRECTION** key to change the rotating direction.
- 5) Press the **START/STOP** key to start or stop the pump.
- 6) Press the **PRIME** key, the pump will run at maximum allowed speed.



Normal Speed

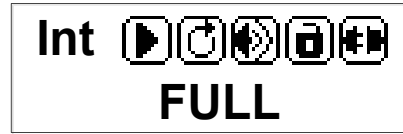

Priming

Figure 12. Normal vs Priming

## 8.5 External Control Mode

On this mode, use external logic level signal to control direction, start and stop; use external analog signal to control rotation speed. The keypad is disabled.



For External Voltage Signal  
0-5V/0-10V



For External Current Signal  
4-20mA

Figure 13. External Control Mode

To control pump by external signal:

- 1) Power off the pump. Wire the DB15 connector as shown in [Figure 14](#) or [Figure 15](#). Connect it to the DB15 port on the rear of the pump.

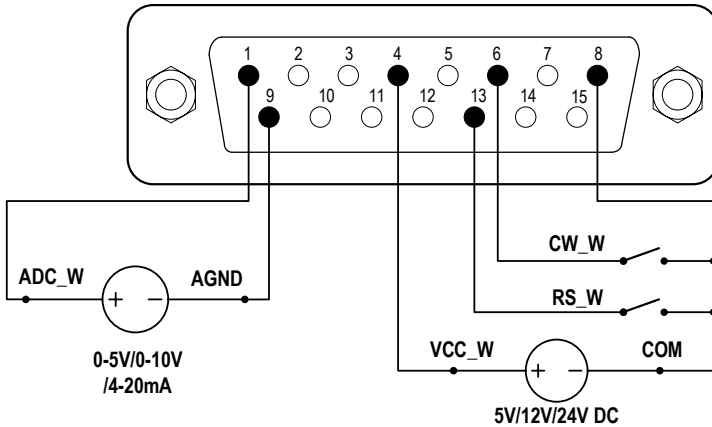

Figure 14. DB15 Wiring with External Power Source

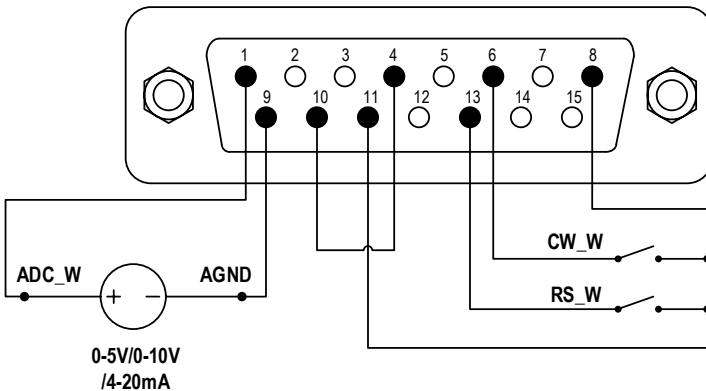

Figure 15. DB15 Wiring with the Internal 12VDC Power Source

- 2) Power on the pump. The pump will display the main screen.
- 3) Use the **MENU** to change the mode to External Control mode (ExtV or ExtI shown on the screen).
- 4) Close the external RS\_W switch, and turn on the external analog signal power source. The speed will change according to the intensity of the input signal. Open the RS\_W to stop the drive.
- 5) Open CW\_W switch, then pump will run in clockwise direction; close the CW\_W switch, then pump will run in counterclockwise direction.

## 8.6 Time Dispense Mode

The pump will dispense fluid automatically by setting duration for each dose, pause time between doses and the number of cycles. When dispensing, the display will show the dispensing time or lag time that has passed (1.2s in Figure 16), and the total cycles (4 in Figure 16) that has dispensed.

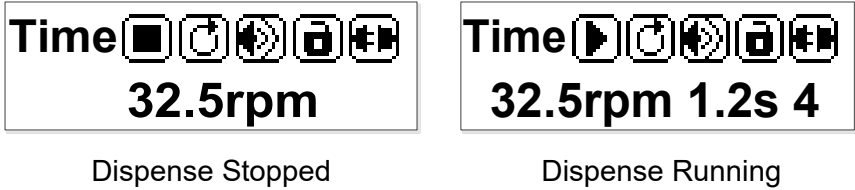

Figure 16. Time Dispense Mode

To set Time Dispense Mode:

- 1) Power on the pump. The pump will display the main screen.
- 2) Use the **MENU** to change the mode to Time Dispense mode (Time shown on the screen).
- 3) Use the **MENU** to set the duration for each dose, the pause time between doses and number of cycles.
- 4) Return to the main screen.

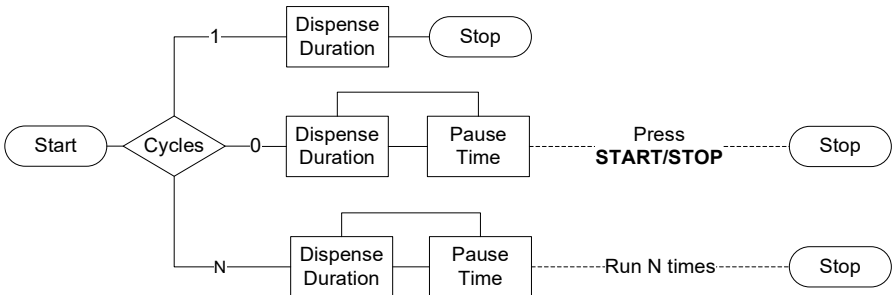

Figure 17. Dispense Cycle Setting

To run Time Dispense:

- 1) Press the **DIRECTION** key to change the running direction, clockwise or counterclockwise.

- 2) Press the **START/STOP** key to start dispensing.
- 3) When the drive is running, press the **START/STOP** key to stop the drive at any time.
- 4) A footswitch can be used to start/stop the pump.

## 8.7 Logic Level 1 Control Mode (footswitch)

Use an external logic-level signal to control the start and stop. Use the keypad to control direction and speed.



Figure 18. Logic Level 1 Control Mode

- 1) Power off the pump. Wire the DB15 connector as shown in [Figure 19](#) or [Figure 20](#), and connect it to the DB15 port on the rear of the pump.

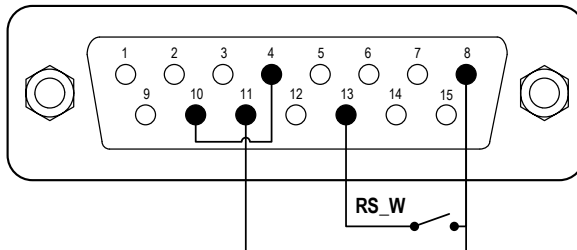

Figure 19. Logic Level 1 Control with Internal 12V Power Source

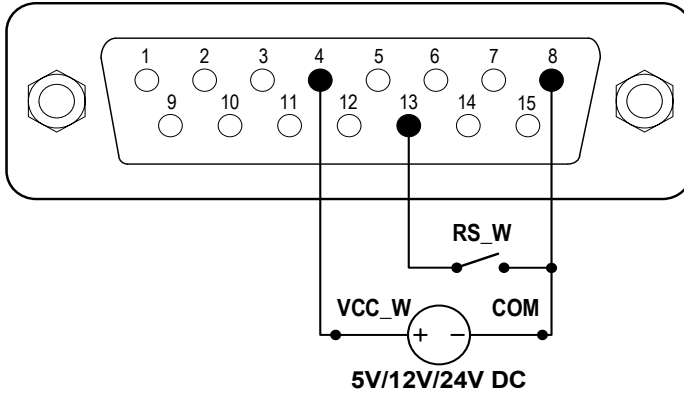

Figure 20. Logic Level 1 Control with External Power Source

- 2) Power on the pump. The pump will display the main screen.
- 3) Use the **MENU** to change the mode to Logic Level 1 control mode (shows Lev1 on the screen).
- 4) Press the **UP** or **DOWN** key to adjust the speed.
- 5) Press the **DIRECTION** key to change the rotating direction.
- 6) When the switch is closed, the drive will start running; when the switch is open, the drive will stop.

## 8.8 Logic Level 2 Control Mode (footswitch and direction switch)

Use an external logic-level signal to control start, stop and direction. Use the keypad to control speed.

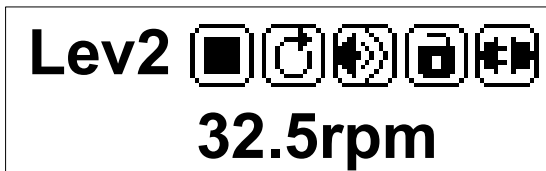

Figure 21. Logic Level 2 Control Mode

- 1) Power off the pump. Wire the DB15 connector as shown in [Figure 22](#)



or Figure 23, and connect it to the DB15 port on the rear of the pump.

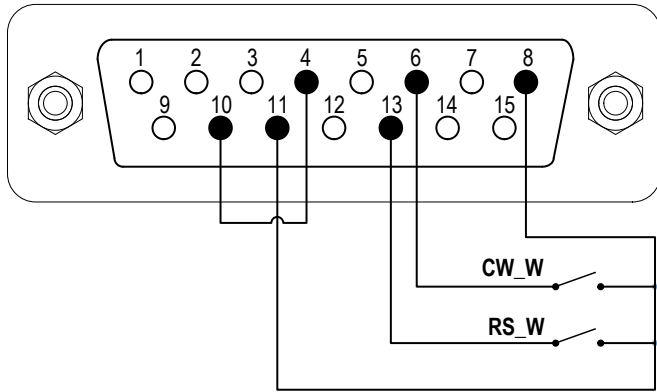

Figure 22. Logic Level 2 Control with Internal 12V Power Source

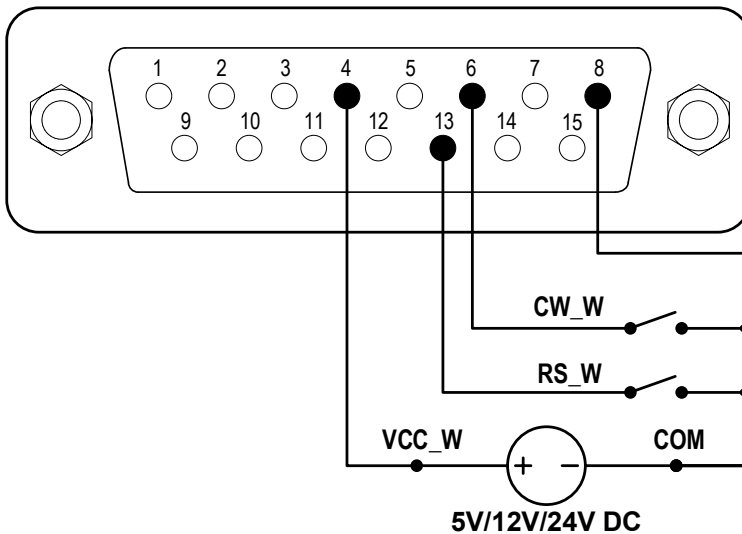

Figure 23. Logic Level 2 Control with External Power Source

- 2) Power on the pump. The pump will display the main screen.
- 3) Use the **MENU** to change the mode to Logic Level 2 control mode (shows Lev2 on the screen).
- 4) Press the **UP** or **DOWN** key to adjust the speed.
- 5) When the switch RS\_W is closed, the drive will be running at the set

speed; when the switch RS\_W is open, the drive will stop.

- 6) When the switch CW\_W is open, the drive will be running in the clockwise direction. When the switch CW\_W is closed, the drive will be running in the counterclockwise direction.

## 8.9 Communication Mode

The RS485 interface supports the standard MODBUS protocol. The pump can communicate with external devices via the communication port. Please refer to the [Communication Instruction manual](#) for the parameters and supported commands.

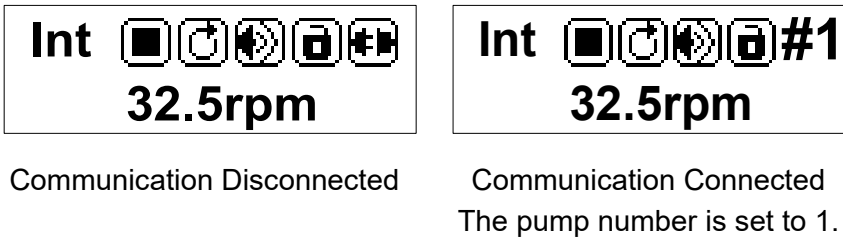

Figure 24. Communication Mode

- 1) When the power is off, wire the DB15 connector as shown in [Figure 25](#) or [Figure 26](#), then connect it to the DB15 port on the rear of the pump. An external DC power source is recommended to avoid electrical interference.

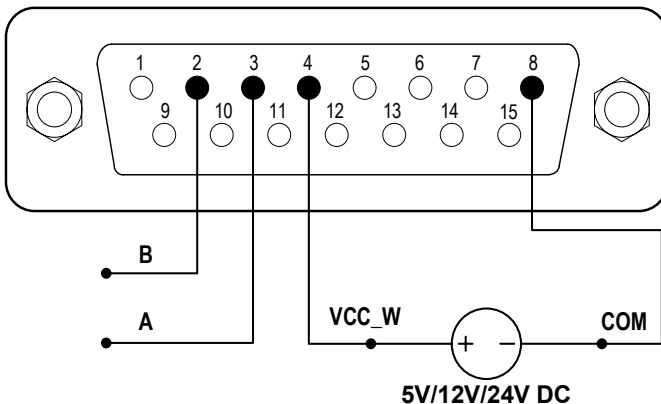

Figure 25. RS485 MODBUS Wiring with External Power Source

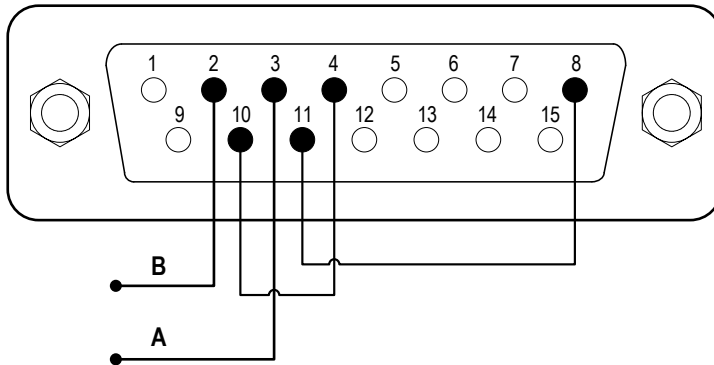

Figure 26. RS485 MODBUS Wiring with Internal 12V Power Source

- 2) Power on the pump. The pump will display the main screen.
- 3) Use the **MENU** to change the mode to Internal Control mode or Time Dispense mode.
- 4) Control pump with the communication interface.
- 5) Press the **START/STOP** key to stop the drive at any time.

## 8.10 Speed Setting

The speed resolution is 0.1 rpm when the speed is between 0.1 and 100 rpm; the speed resolution is 1 rpm when the speed is between 100 and 600 rpm. On the main screen, the speed can be set by pressing the **UP** or **DOWN** key. Pressing the **UP** or **DOWN** key shortly, the last digit of the value will change by 1. Hold the **UP** or **DOWN** key to change the value fast.

Hold the **PRIME** key, then press the **UP** key to set the speed to the maximum directly; hold the **PRIME** key, then press the **DOWN** key to set the speed to the minimum (0.1 rpm) directly.

## 9 Maintenance

### 9.1 Warranty

The product comes with one-year labor and parts warranty. The limited warranty does not cover any damage that is caused by improper usage and handling.

## 9.2 Regular Maintenance

- 1) Always check the tubing and connections to avoid leakage.
- 2) Do not cover the fan on the rear of the pump.
- 3) Do not use water to wash the pump. Keep the pump head dry.
- 4) Do not use chemical solvents to clean the pump and pump head.

## 9.3 Malfunction Solutions

No.	Mal-function	Description	Solution
1	Hardware	No display	<ol style="list-style-type: none"> <li>1. Check the power cord</li> <li>2. Check the internal power cord connection inside the pump.</li> </ol>
2	Hardware	The motor does not work	<ol style="list-style-type: none"> <li>1. Check the indicator of the driver board.</li> <li>2. Check the wire connection between the motor and the driver board.</li> <li>3. Check the wire connection between the driver and the mainboard.</li> <li>4. Check the power voltage for the pump.</li> </ol>
3	Hardware	Motor is trembling	<ol style="list-style-type: none"> <li>1. Check the wire connection between the motor and the driver board.</li> <li>2. The motor is overloaded. Check the mechanical connection.</li> </ol>
4	Hardware	Motor only runs in one direction	Check the connection between the drive board and the main control board.
5	Hardware	The keypad does not work	<ol style="list-style-type: none"> <li>1. Check the wire connection between the keypad and the mainboard.</li> <li>2. Check if the key is broken.</li> </ol>
6	Hardware	External control does not work	<ol style="list-style-type: none"> <li>1. Check the wiring of the connector.</li> <li>2. Check if the external control power voltage is provided.</li> <li>3. Check the connections of the external control board.</li> </ol>

7	Hardware	RS485 com does not work	<ol style="list-style-type: none"> <li>1. Check the wiring of the connector.</li> <li>2. Check if the external control power voltage is provided.</li> <li>3. Check the connections of the communication board.</li> </ol>
8	Hardware	Noisy when running	Check the screws and level on the pump head to make sure they are secure.
9	Software	External control does not work	Check if the pump is on External Control Mode.
10	Software	RS485 does not work properly	<ol style="list-style-type: none"> <li>1. Check if the display shows that the communication is ready.</li> <li>2. Reset the address of the pump.</li> <li>3. Check whether on the bus there are two pumps using the same address</li> </ol>



If the problem cannot be solved, please contact the manufacturer or distributor.

## 10 Dimensions

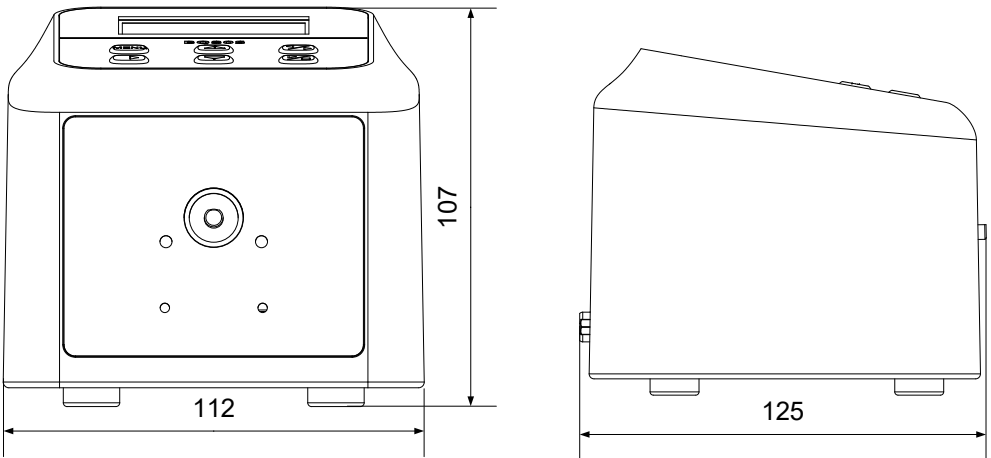
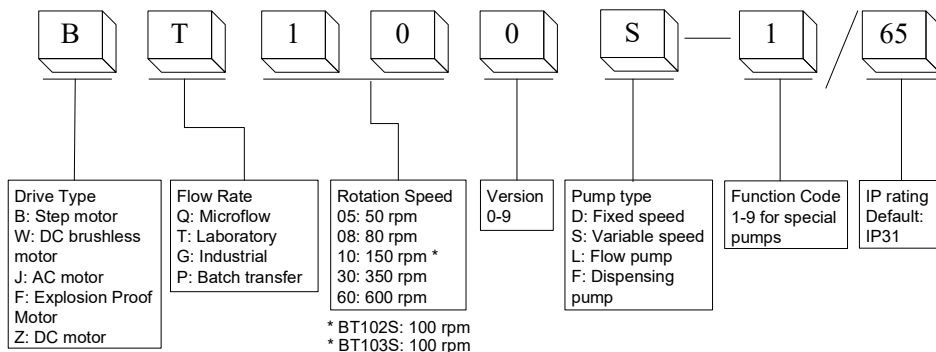

Figure 27. Dimensions (mm)

## 11 Naming Rule



## 12 Specifications

Suitable pump heads	DW10, FZ10, WY10, KD10, KD15, KJ15, DW15
Speed	0.1-80rpm, 0.1 rpm resolution
Flow rate	0.004-77 mL/min
Speed accuracy	0.5%
Time range	0.1-999 sec/min/hour
Power supply	24V DC
Power consumption	10W
External logic level control signal	5V, 12V, 24V
External analog control signal	0-5V, 0-10V, 4-20mA
Communication interface	RS485 MODBUS
Operating condition	Temperature 5-40°C Relative humidity <80%
IP grade	IP31
Display	128x64 LCD
Dimensions (LxWxH)	125x112x107mm(4.9x4.4x4.2inch)
Weight	1 kg (2.2 lbs)

**BQ80S Suitable Pump Heads and Tubing, Flow Parameters**

<b>Pump Head</b>	<b>No. of Channels</b>	<b>Tubing size (mm)</b>	<b>Flow rate per channel (mL/min)</b>
FZ10	1	Wall Thickness 0.8-1, ID≤3.17	0.05-40
DW10-1	1	Wall Thickness 0.8-1, ID≤3.17	0.005-32
DW10-2	2	Wall Thickness 0.8-1, ID≤2.54	0.005-19
DW10-3	3	Wall Thickness 0.8-1, ID≤3.17	0.005-32
KD10-1/2	1/2	Wall Thickness 0.8-1, ID≤3.17	0.004-32
KD15-1	1	13# 14# 16# 19# 25#	0.004-77

**Golander LLC**

4405 International Blvd  
Ste B117, Norcross, GA 30093  
USA

Tel: +1 678-587-8806

[info@golanderpump.com](mailto:info@golanderpump.com)

[www.golanderpump.com](http://www.golanderpump.com)

**Golander GmbH**

Dechant-Heimbach-Str. 29  
53177 Bonn  
Germany

Tel: +49 228 50446952

[info@golander.de](mailto:info@golander.de)

[www.golander.de](http://www.golander.de)